

# HVDC Standardisation

Richard Cooke  
29/06/2010

GRID |



**ALSTOM**

# Agenda

Introduction of ALSTOM Grid

Page 3

Why Standardisation for HVDC

Page 6

Situation Today

Page 8

Arenas for Standards to Develop

Page 13

Open Issues

Page 19

# Alstom group : Three main activities

*In the top 3 in its main activities*

## Rail transport infrastructure

*Alstom makes 1 metro in 4 and 1 tram in 4*



## Power generation infrastructure

*Alstom supplies major equipment in 25% of the worldwide installed power generation capacity*



## Power transmission infrastructure

*Strong positions in key markets and technologies (Network Management, GIS, HVDC, Disconnectors, Instrument Transformers...)*

**Alstom  
Grid**



# Alstom Grid : Key Figures

## New growth potential for the Group

- Among the Top 3 in electrical Transmission with a 12.5% global market share
- 20,000 employees
- €3.5 billion sales in 2009
- Over 90 manufacturing and engineering sites worldwide
- 4 main businesses: Products, Systems, Automation, Service
- Strong positions in key markets and fast-growing technologies (Network Management, GIS, HVDC, Disconnectors, Instrument Transformers...)



# Agenda

Introduction of ALSTOM Grid

Page 3

Why Standardisation for HVDC

Page 6

Situation Today

Page 8

Arenas for Standards to Develop

Page 13

Open Issues

Page 19

# Do We Need to Standardise?

## Why Standardisation for HVDC

### Purpose of Standards

- Reduce costs (design one build many, long run cost reductions etc.)
- Reduce barriers to entry for component suppliers
- Improve safety through improved operability (common processes, common documentation formats etc.)
- Improve asset availability through improved maintainability (common or interchangeable spares, common tooling etc.)
- Support interoperability
- Allowing interconnected systems to be built incrementally and by different equipment suppliers, thus support incremental investment plans and avoid “stranded assets”
- Allow separation of cable and converter procurement thus allowing buyers to take advantage of the increasing number of HVDC cable manufacturers
- Avoid wasted R&D investment (Betamax vs VHS scenario) by technology developers

### Nature of HVDC Industry

- Due to LCC technology each project was a bespoke design
- Technological innovation has been a key competitive advantage

# Agenda

Introduction of ALSTOM Grid

Page 3

Why Standardisation for HVDC

Page 6

Situation Today

Page 8

Arenas for Standards to Develop

Page 13

Open Issues

Page 19

# Situation Today

## Point to Point Thinking

### UK OFTO Regime

- UK Govt. Decision in March 2007 to not adopt zonal OFTO with the rationale that non-exclusive licenses:
  - Delivers cheaper and more timely offshore grid connections
  - Encourages innovation through competition and enable new entrants to compete in the market
  - Is more focused on generators' requirements than the onshore system or the exclusive approach
  - Allows generators to bid to own their own transmission assets, making the adoption issue easier to solve and creating more certainty for generators.

### Latest National Grid ODIS

- In their first Offshore Development Information Statement NG as GBTSO foresee:
  - A converter block size of 1000MW operating as a bipole via 300kV DC cable connection
  - 29 zone to shore point to point connections for Round 3

# Situation Today

## The Interconnected Grid

### Interconnectors

- Nordbalt
  - E.oN ambition to connect Södra Midjösbanken offshore wind project
- Cobra
  - Dutch or German wind project DC hubs (Tennet as common Shareholder)
- Shetland Link
  - EERP funds for intermediate DC Hub to connect offshore wind and marine generation



### Renewable Generation

- Kriegers Flak
  - Original ambition to interconnect projects in three territorial waters (Germany, Denmark & Sweden)

### North Seas Grid Initiative

- Penta +
  - Ten Governments commitment to an interconnected North Sea grid signed at the end of 2009

# Issues that drive DC Grids

## EC Energy Policy

Laid out in 2008 “Green Paper” and at the core of the “Third Package”

- Ensure **secure** network operation
  - TEN-E, priority interconnections, SET-Plan
- Establish a single European energy market, i.e. increase **competitiveness**
  - TEN-E, priority interconnections
- Develop the energy in a **sustainable** manner
  - 20 / 20 / 20 targets

Interconnection with and within several “peripheral” regions is high on the EC’s agenda:

- Baltic region
- Irish region
- Mediterranean region

Note: The EC recovery package published in 2009 identified 8 interconnection projects to be “supported” (900 MEUR), out of which 5 could be DC

# Technical issues for DC Grids

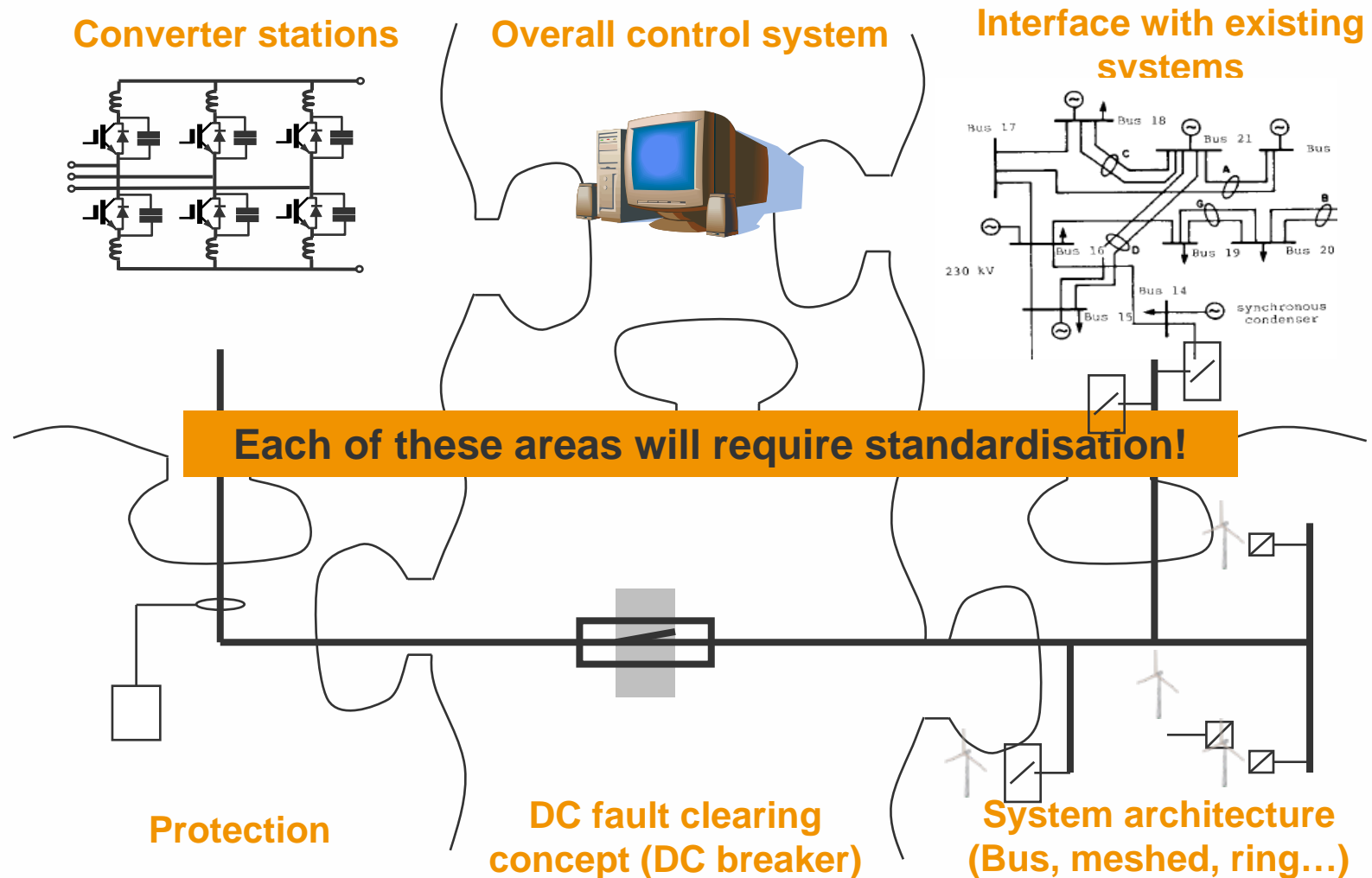

# Agenda

Introduction of ALSTOM Grid

Page 3

Why Standardisation for HVDC

Page 6

Situation Today

Page 8

Arenas for Standards to Develop

Page 13

Open Issues

Page 19

# Collaborative Activities

## TWENTIES EC Project

Objective: prepare European networks for a massive wind penetration (26 partners, led by Red Electrica de Espana)

***Integrate intermittent generation***

***DEMO: Services by wind farms***

***DEMO: Flexible demand***

***Prepare offshore grids roll-out***

***DEMO: DC breaker***

***DEMO: Storm control for wind farm***

***Make grids flexible***

***DEMO: WAMS and advanced operational tools***

***DEMO: Novel FACTS and network management***

AREVA T&D involved with a budget of nearly 3 million EUR



GRID

**ALSTOM**

# Collaborative Activities

## TWENTIES Project – WP? DC Breaker

- Work package goal: specify and demonstrate the critical component for multi-terminal grids, the DC breaker
- Candidate technologies:

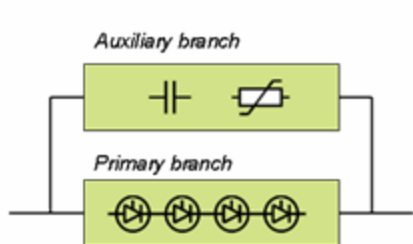

*Power electronic switch*

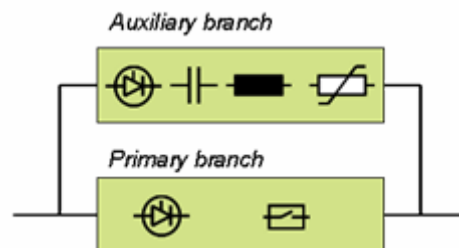

*Hybrid switch*

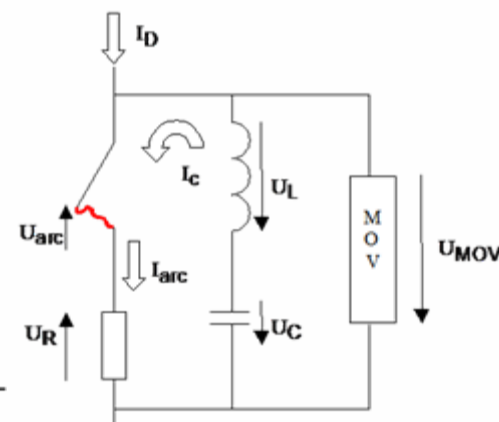

*Mechanical switch*

- Work package contributions to pre-standardisation work
  - Identification of possible system architectures (**Voltage and power levels: “educated guesses”**)
  - Identification and description of breaker duties
  - Matching between technical capabilities and anticipated requirements

# Industry Initiatives

## DNV – OS J201 Offshore Substations for Wind Farms

### Background

- Joint Industry Project (JIP) proposed by DNV commenced October 2008.
- Main participants were DONG, StatOilHydro, Vattenfall, Energinet and E.ON plus manufacturers ALSTOM Grid and Siemens.

### Objective

- To provide a standard for safety requirements for offshore transformer (AC and DC) and accommodation platforms associated with offshore wind farms and other renewable energy projects.

### Scope

- Safety philosophy and formal assessment
- Arrangement principles (segregation of platforms and areas, location of equipment, manning, welfare)
- Structural design
- Electrical design
- Fire and explosion protection
- Access and transfer
- Emergency response
- Construction
- In-service inspections and maintenance

### Status

- The final document was published in November 2009. DNV intend to update and expand the section on “Electrical Design” in 2011.

# Industry Initiatives

## CIGRE WG B3:26

### “Guidelines For The Design And Construction Of AC Offshore Substations For Wind Farms”

The aim of the activity is to:-

- Identify the key issues which impact on the design and construction of these substations
- Provide constructive guidelines to designers, developers and constructors to assist them in addressing these issues in order to develop cost effective practical and sustainable solutions to these challenges.

Final brochure by mid 2011.

This WG will consider installation methods, foundations, maintenance requirements, cable access, control, conditioning monitoring etc.

But HVDC outside of the scope of this Working Group.

# Commercial Developments

## VSC HVDC Converter Manufacturer Highlights

### ABB

- Pioneer with PWM technology
- Delivered BorWin Alpha DC hub in German North Sea
  - Final Commissioning awaiting Bard 1 wind farm completion
- Next generation will use multi-level converter

### ALSTOM Grid

- 20MW Demonstrator multi-level converter being commissioned in August 2010
  - Installed in Stafford, UK
  - Inherent ability to block DC side faults
  - Ability to reverse polarity allowing a tap on a classical LCC system

### Siemens

- Recently awarded BorWin Beta DC Hub in German North Sea
- Currently commissioning first VSC HVDC link (Transbay, California) based on multi-level converter

Where should the standardisation limits be drawn to allow technical differentiation be an engine for innovation?

# Agenda

Introduction of ALSTOM Grid

Page 3

Why Standardisation for HVDC

Page 6

Situation Today

Page 8

Arenas for Standards to Develop

Page 13

Open Issues

Page 19

# Open Issues

## Cable Voltages/Control Concepts

### Cable Voltages

- Seen as a key issue to resolve to allow interconnected grid systems to be realised
  - 300kV vs 320kV
- Strong R&D Activity amongst existing European players
- New entrants in European market
  - NKT
  - J Power ?
  - ....
- New Cable Maintenance Initiatives
  - Modelled on telecoms cable market
    - NSW are proposing a model based on the services provided by ACMA and MECMA for telecoms cable owners
- Performance improved by commonality of cable ancillaries

### Control Systems

- For a meshed grid power flow magnitude and direction will need to be communicated between converter “nodes” from potentially different OEMs

# Open Issues

## Converter Block Sizes

Key to design once, build many

- 400MW vs 500MW vs 800MW vs 1000MW
- Topside structure design a key cost/investment in realising offshore substations
- Certainty can release (further) optimisation
- Driver or driven by cable voltage selection?

Geographical coverage

- National markets (Germany's focus on 80 turbine projects)  
or
- European wide/Global

Impact on Installation Vessel investment

- Possibly low due to self installing designs
- Suitability for all ground conditions/water depths?

# Open Issues

## What Forum Should Lead Resolution?

### Potential Forums for Resolving Outstanding Issues

- CIGRE
- IEC
- ??

#### CIGRE

- Develops recommendations not formal standards
- Can end up being non specific and takes several years
- Potentially Suitable WG already formed, Technical Brochure due to be delivered in 2011

#### IEC

- Needs a National Committee to propose and be accepted
- Also takes several years to complete
- However produces internationally accepted standards and can act to “formalise” CIGRE recommendations

## CIGRE WG B4:52 DC Grids

### Scope

- For DC Grids the security and reliability of supply will be very important factors. Any fault on the DC Grid would be felt over a very long distance, since the inductance only provides temporary fault current limitation, the WG will examine ways to prevent the effect of fault at remote locations.
- Costs will form an important role in determining the feasibility of DC Grids, and the working group will draw on work already done within CIGRE to identify the relative costs of ac and dc alternatives. Note that in some cases the only option for additional transmission capacity will involve cables.
- The WG will look at various Grid configurations such as radial and meshed nets, from the viewpoint of reliability and controllability and finally look at a complete HVDC grid.
- As a grid has more branches than nodes the methodology to achieve power flow control will be investigated.
- Loss of a whole grid should in principle never happen. This puts requirements on the structure of the net with sufficient redundancy, need for sectionalisation of the net by HVDC breakers and protections for first, second and third zone. Whilst dc breakers and protections have yet to be developed, the WG can look at identifying the necessary breaking current capabilities and times.
- Starting from the standard voltage levels used for AC networks, the WG will look at the possibility of recommending standard voltages for DC Grids.
- The WG will discuss the aspects of the converter station design that may need to be standardised, such that stations from different manufacturers can be connected to a dc grid.

The Key Forum for (Offshore Wind) HVDC Standards ?

# Summary & Conclusions

## Will Standardisation Happen?

OFTO Regime does not drive Standardisation

- Developer consenting activity may or may not open the door

EC Policy/Penta + Declaration provides stronger drive

- 3<sup>rd</sup> Package with Single TSO, Single Regulator will help
- The problem of common renewables tariffs remains

Multiple forums exist through which standards and standardisation can be achieved

- Which forum should the UK Offshore Wind industry support?

Extent of useful standardisation still to emerge

- In the short term DC cable voltages and converter block sizes are probably sufficient
- Longer term balance to be found between volume and innovation

[www.alstom.com](http://www.alstom.com)

**ALSTOM**